

Bracket Assy.	711464 (Inc. items 1-3, 18, 23)
Bolt Packages:	
Bracket	711465 (Inc. items 8-11, 19)
Pulley	None
Idler	711450 2 Ea. (Inc. items 4, 20, 22)
Tensioner	None

Make	Dodge
Engine	5.9L
Fuel	Diesel
Year	2003-
Equipment	Turbo, without A/C
Revised	B 11-9-04

Item	Part No.	Description
------	----------	-------------

1.	711440	Engine bracket	15.	711452	1/2" Hose, 2.00" long
2.	711441	Alternator bracket	16.	OEM	Air Filter Restriction Indicator
3.	711442	Idler bracket	17.	-----	-----
4.	711443	Idler bushing, 1.275"	18.	711463	Idler bracket, without a/c
5.	740261	Idler pulley, flat	19.	110260	M8 x 25 x 1.25 Bolt
6.	*	Pump	20.	110544	7/16-14 x 2 Bolt
7.	740148	Clutch	21.	710936	Pump plate
8.	110435	3/8-16 x 1 1/2 Bolt	22.	110670	7/16 Flat washer
9.	110465	3/8-16 x 1 1/4 Socket head bolt	23.	711657	Bracket, fan shroud support
10.	110176	M10 x 35 x 1.5 Socket head bolt	24.	110486	M8 x 1.25 x 30 Bolt
11.	OEM	Bolt	25.	-----	-----
12.	110425	3/8-16 x 1 1/4 Bolt	26.	110141	M8 x 1.25 Wiz flange nut
13.	110676	3/8 Flat washer	27.	110069	5/16-18 Flat washer
14.	120354	Elbow	28.	740263	Belt, Poly-Cog 1380K8

FIG. 1

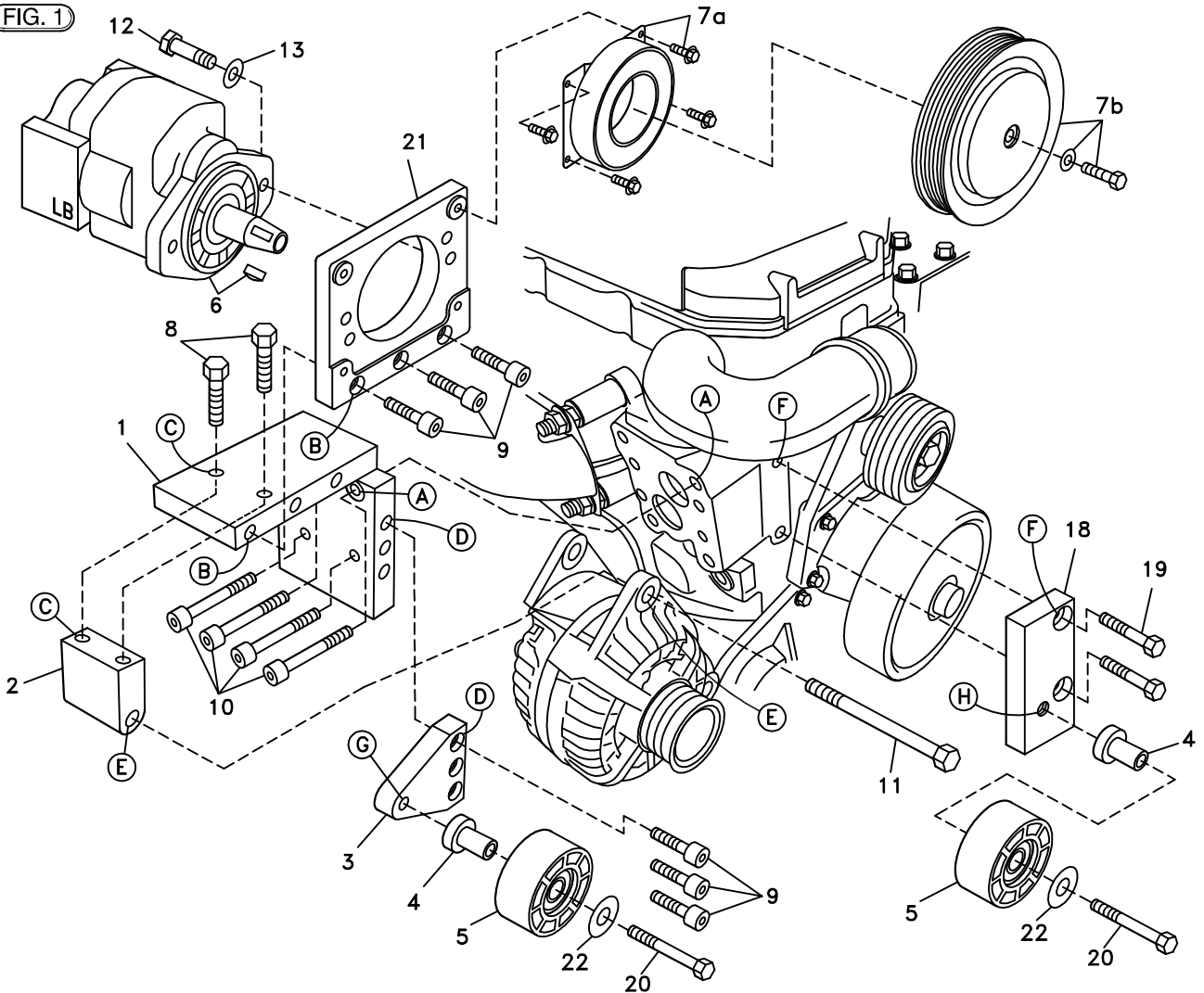

(A),(B),(C)... Denotes bolt holes in engine to locate corresponding holes in Pump Brkt.

FIG. 2

AIR FILTER RESTRICTION INDICATOR RELOCATION

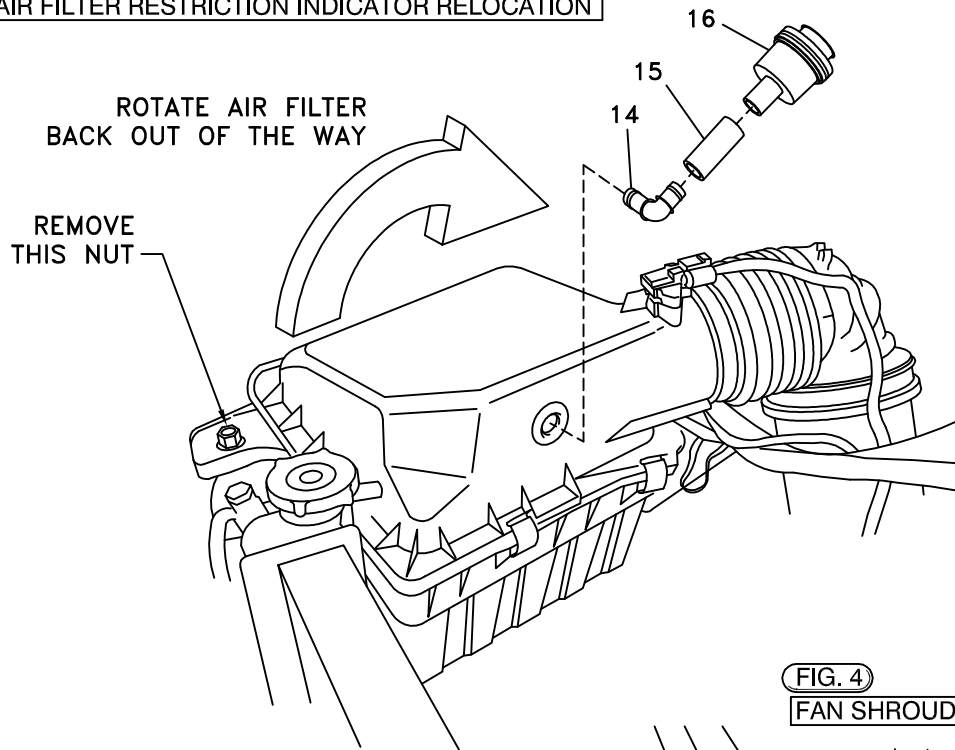

FIG. 3

BELT DIAGRAM

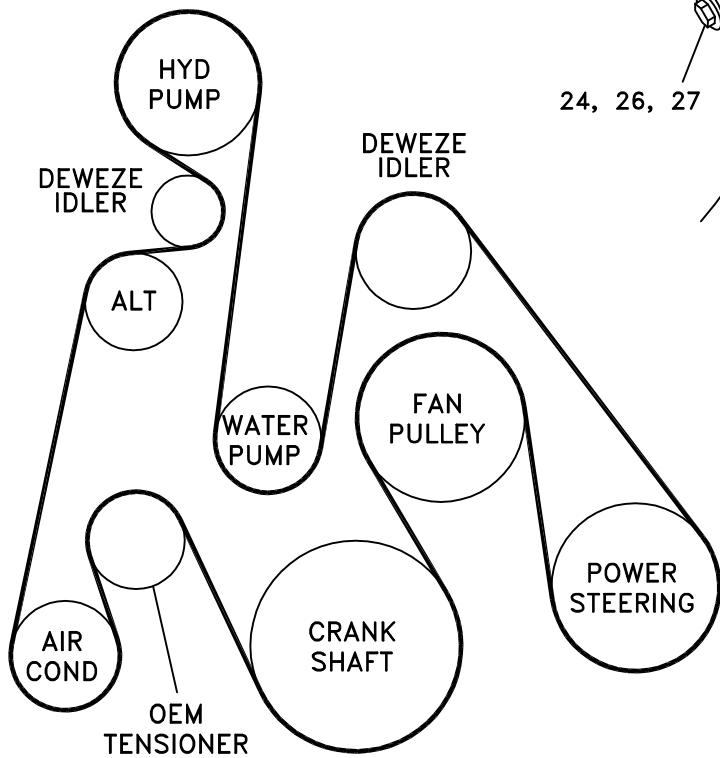
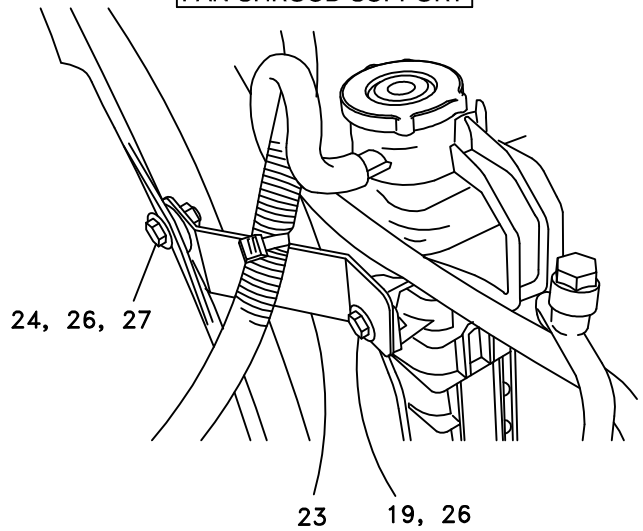

FIG. 4

FAN SHROUD SUPPORT



DewEze

Clutch Pump Kit

Clutch Pump Kit
700402
Dodge 5.9
Diesel
Without A/C
2003-

INSTALLATION INSTRUCTIONS

1. Disconnect the battery.
2. Remove the nut holding the front of the air filter housing. Lay the housing back out of the way. See Fig. 2.
3. Remove the OEM fan shroud support bracket from the front of the engine. Replace it with the flat support bracket (23) in the kit. Attach with M8 x 25 bolt (19) and 5/16" flat washer (27) into radiator. Insert the M8 x 30 bolt (24) into the 5/16" flat washer (27), through the hole in the shroud, through the bracket, and into the M8 nut (26).
4. Remove the OEM belt.
5. Remove the top alternator bolt. Loosen the bottom alternator bolt and pivot the alternator out away from the engine.
6. Remove the top alternator bracket and the lifting lug.
7. Mount the engine bracket (1) to the engine at Location A with four M10 x 35 bolts (10). Attach the top alternator bracket (2) to the underside of the engine bracket at Location C with two 3/8 x 1 1/2 bolts (8). Attach the top of the alternator to the alternator bracket at Location E with the OEM bolt (11).
8. Mount the triangular idler bracket (3) to the engine bracket with three 3/8 x 1 1/4 socket head bolts (9) at Location D. Mount the rectangular idler bracket (18) to the engine with two M8 x 25 bolts (19) at Location F.
9. Insert one idler bushing (4) into each of the flat idlers (5). Mount one idler to the idler bracket (3) at Location G with a 7/16 x 2 bolt (20) and 7/16 flat washer (22). Mount the other idler to the idler bracket (18) with a 7/16 x 2 bolt (20) and 7/16 flat washer (22).
10. Mount the pump (6) to the back of the pump plate (21) with two 3/8 x 1 1/4 bolts (12) and two 3/8 flat washers (13). Bolt the pump plate with pump to the engine bracket with three 3/8 x 1 1/4 socket head bolts.
11. Mount the clutch coil (7a) to the pump bracket with four 1/4 x 1/2 flange bolts (7b). Mount the clutch pulley (7c) to the pump shaft with the 5/16 x 1 1/4 bolt (7d) and heavy flat washer (7e) making sure the key is in place on the shaft.
12. Install the belt (23) as shown in the diagram (Fig. 3).
13. Pull the OEM air filter restriction indicator (16) out from the air filter housing (Fig. 2). Push the plastic elbow (14) into one end of the 1/2" hose (15) and the indicator into the other end of the hose. Insert the plastic elbow into that hole in the housing pointing it to the rear. Lay the air filter housing down to its original position. Replace and tighten the OEM nut holding the air filter.
14. Reconnect the battery.
15. Run the engine and check for any clearance or alignment problems. Adjust as needed.