

Ford F-750 Cummins 6.7L : D, 2009+, A Pump, Rear Port

BOLT PACKAGES:

BRACKET	711975 (Inc. item 10-12, 18, 23)
IDLER PULLEY	None
CRANK PULLEY	711976 (Inc. item 6, 14, 16)
TENSIONER	None
FAN SPACER	None

3-30-09 ISSUE DATE NC 3-30-09 REVISION DATE

Item Part No. Description

1.	711965	Engine bracket	13.	OEM	Bolt
2.	711966	Alternator base plate	14.	110493	3/8-16 x 2 1/4 Bolt
3.	711967	Pump plate	15.	110425	3/8-16 x 1 1/4 Bolt
4.	711968	Block, alternator mounting	16.	110676	3/8 Flat washer
5.	711969	Brace radiator tube	17.	OEM	Nut
6.	711785	Idler bushing	18.	110820	Hose clamp, 3"
7.	740261	Idler	19.	110434	1/4-20 x 1/2 Flange bolt
8.	*	Pump	20.	110290	1/4-20 Flange Nut
9.	742009	Clutch	21.	732023	Battery cable extension, positive
10.	110526	M10 x 1.5 x 40 Bolt	22.	732024	Battery cable extension, negative
11.	110395	3/8-16 x 1 Socket head bolt	23.	110689	M10 Lock washer
12.	110711	3/8-16 x 2 Socket head bolt	24.	742074	Belt, Micro-V K081115

FIG. 1
BELT DIAGRAM

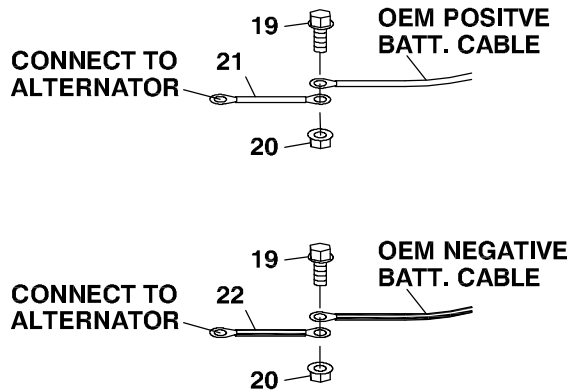
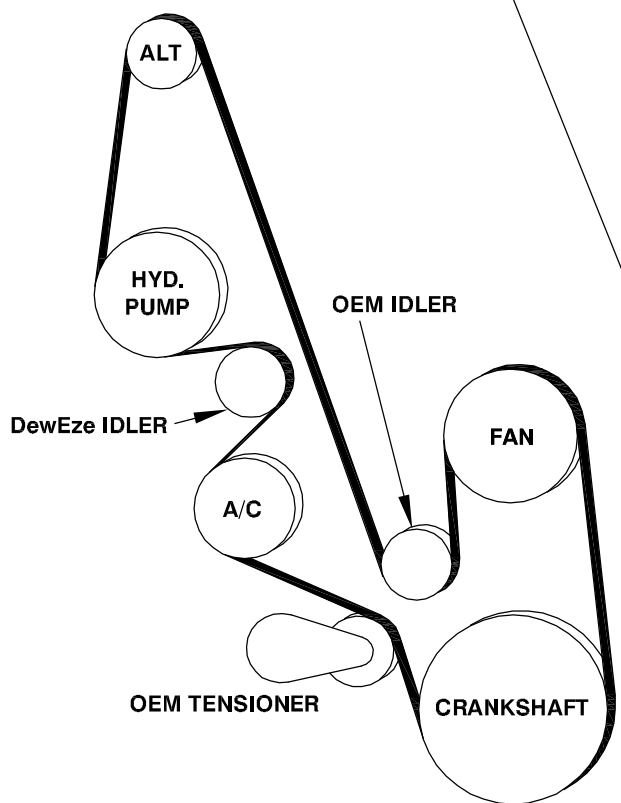

FIG. 2
ALTERNATOR CABLE EXTENSIONS

FIG. 4
GRIND OEM ALTERNATOR BRACKET

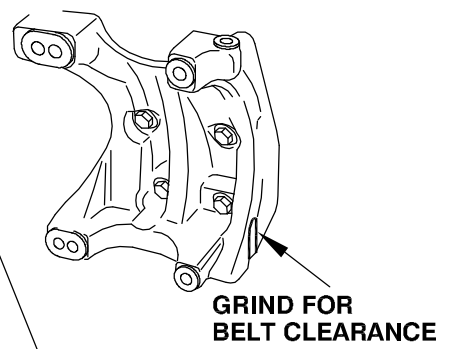
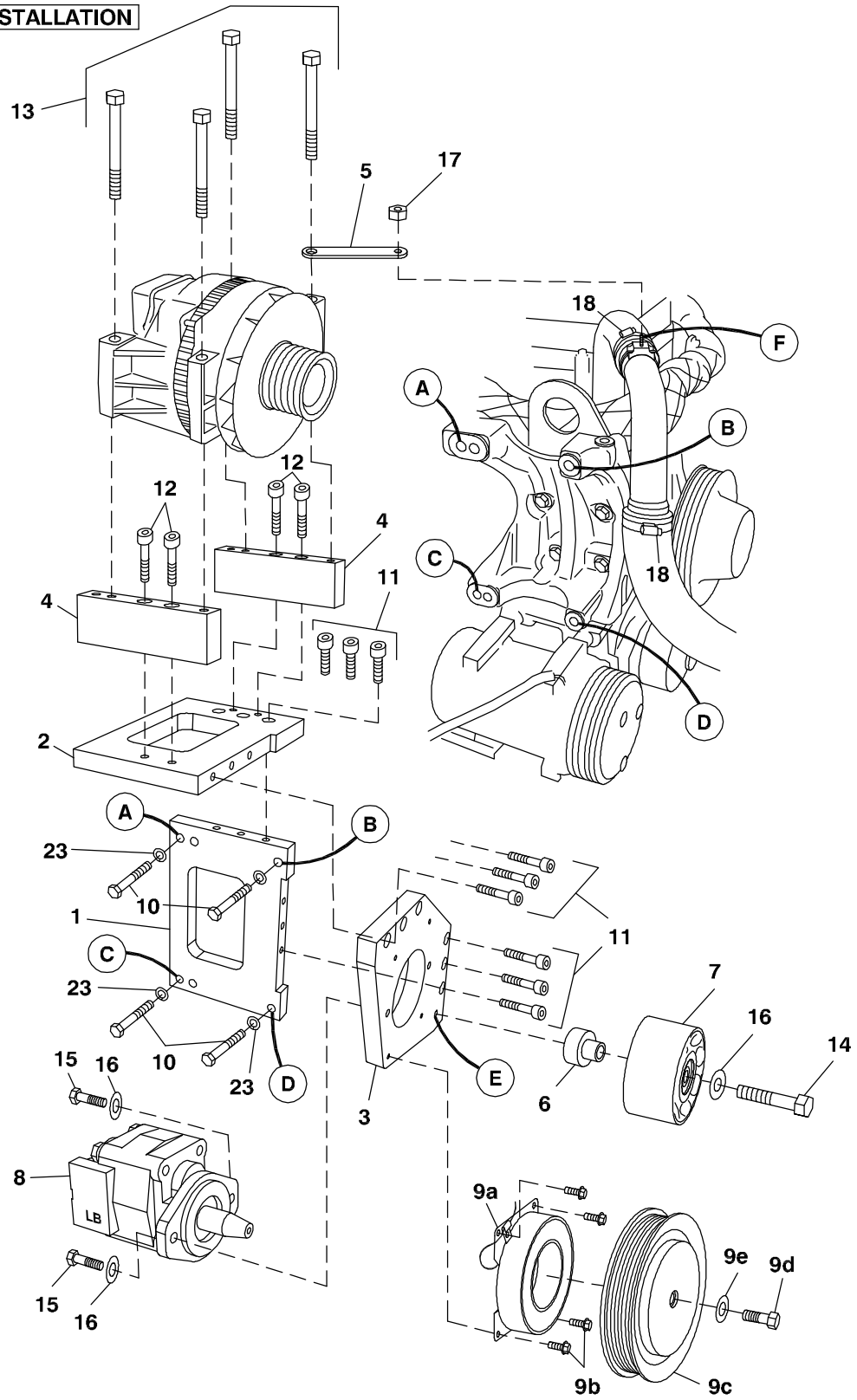

FIG. 3
BRACKET INSTALLATION



DewEze Clutch Pump Kit 700496

Ford F-750, 6.7L Cummins, 2008+

INSTALLATION INSTRUCTIONS

1. The installation of this kit requires trained decision-making concerning clearances, tying components together, rerouting, or relocating OEM components, etc. It is impossible to describe all of the clearance and vibration points, etc. in the installation instructions. Therefore, the technician must exercise professional judgment to achieve the best quality installation.
2. Disconnect the battery. Remove passenger's side intercooler tube for access. Drain radiator enough to remove upper radiator hose on passenger side. Remove radiator hose and metal tube. Note: This hose may have heat shrink "Power Grip" clamps which must be cut to remove. Remove four clamps on hose and metal tube also; hose clamps will be replaced with standard hose clamps. Remove belt.
3. Remove cables from alternator, noting positions for reassembly. Remove alternator and set aside.
4. Install vertical engine bracket (1) to the OEM alternator bracket location with the four M10 x 40 bolts (10) at Locations A, B, C, and D. Bolt on horizontal alternator base plate (2) with three 3/8 x 1 socket head bolts (11). Bolt pump (8) onto pump plate (3) with two 3/8 x 1 1/4 bolts (15) and two 3/8 flat washers (16). Install pump plate with six 3/8 x 1 socket head bolts (11).
5. Install clutch. Install idler pulley (7) with idler bushing (6) using the 3/8 x 2 1/4 bolt (14) and 3/8 flat washer (16) to Location E. Install two alternator riser blocks (4) with two 3/8 x 2 socket head bolts (12) each.
6. Install alternator with the four OEM bolts (13). Brace (5) will be placed under one alternator bolt as shown in Fig. 1. Do not tighten that bolt yet.
7. Attach extension cables (21, 22) to existing alternator cables with 1/4 x 1 flange bolts (19) and 1/4 flange nuts (20). Attach cables to alternator, making sure to connect the same way as OEM.
8. Install the pump belt (24). If the belt contacts the OEM alternator bracket, grind the casting for clearance as in Fig. 4.
9. Reinstall radiator hose and tube with steel hose clamps (18) twisting the hose for clearance. Attach the brace (5) to stud on the clamp on the tube with the OEM nut (17). Tighten the alternator bolt. Refill radiator with coolant.
10. Install intercooler tube. Reconnect the battery.
11. Run the engine and check for any clearance or alignment problems. Adjust as needed.