

**SUPER  
SLICER**

RECORD WARRANTY INFORMATION HERE:

Purchase Date: \_\_\_\_/\_\_\_\_/\_\_\_\_

Dealer: \_\_\_\_\_

Model Number: \_\_\_\_\_

Serial Number: \_\_\_\_\_

9/93

TABLE OF CONTENTS

SET-UP INSTRUCTIONS.....1-2

OPERATING INSTRUCTIONS.....3-8

MAINTENANCE INSTRUCTIONS.....9

PARTS LISTINGS

    FORK.....10

    TRAILER.....10

    BACKBOARD AND SIDEBBOARD.....11

    SICKLE DRIVE.....12-13

    TABLE ASSEMBLY.....14-15

    HYDRAULICS ASSEMBLY.....16

PARTS LISTING OF PTO OPTION

    TABLE ASSEMBLY.....18-19

    HYDRAULICS ASSEMBLY.....20

WARRANTY INFORMATION.....BACK COVER

1  
2  
3  
4  
5  
6  
7  
8  
9  
10  
11  
12  
13  
14  
15  
16  
17  
18  
19  
20  
21  
22  
23  
24  
25  
26  
27  
28  
29  
30  
31  
32  
33  
34  
35  
36  
37  
38  
39  
40  
41  
42  
43  
44  
45  
46  
47  
48  
49  
50  
51  
52  
53  
54  
55  
56  
57  
58  
59  
60  
61  
62  
63  
64  
65  
66  
67  
68  
69  
70  
71  
72  
73  
74  
75  
76  
77  
78  
79  
80  
81  
82  
83  
84  
85  
86  
87  
88  
89  
90  
91  
92  
93  
94  
95  
96  
97  
98  
99  
100

## SET-UP INSTRUCTIONS

Your DEWEZE SUPER SLICER is shipped from the factory in a "knocked-down" position to make it easier to transport. If it is necessary for you to transport your Super Slicer you will again need to "knock it down" in order to get within the legal limits of most public roads. If transport is necessary or if you have received your machine in the "knocked-down" position follow the instructions below to set it up correctly.

1. Raise the backboard (1) into an upright position and secure loosely with two 1/2" bolts (5) provided on each end. (See Sketch A)

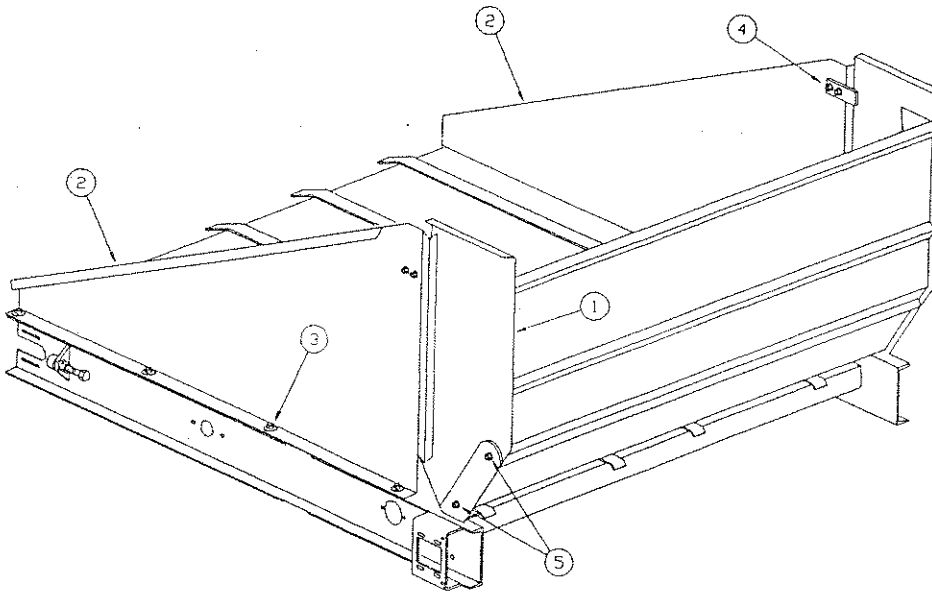

SKETCH A

2. Set sides (2) in place and fasten down with five 5/16" bolts (3) located on the table sides.
3. Tighten top hold-down brackets (4). (See Sketch A).
4. Tighten four 1/2" bolts described in instructions 1 above.

SET-UP INSTRUCTIONS (continued)

5. Slide the table into the feeding position (away from the loading arm) and secure with bolts (1) provided, one at each end.  
(See Sketch B)

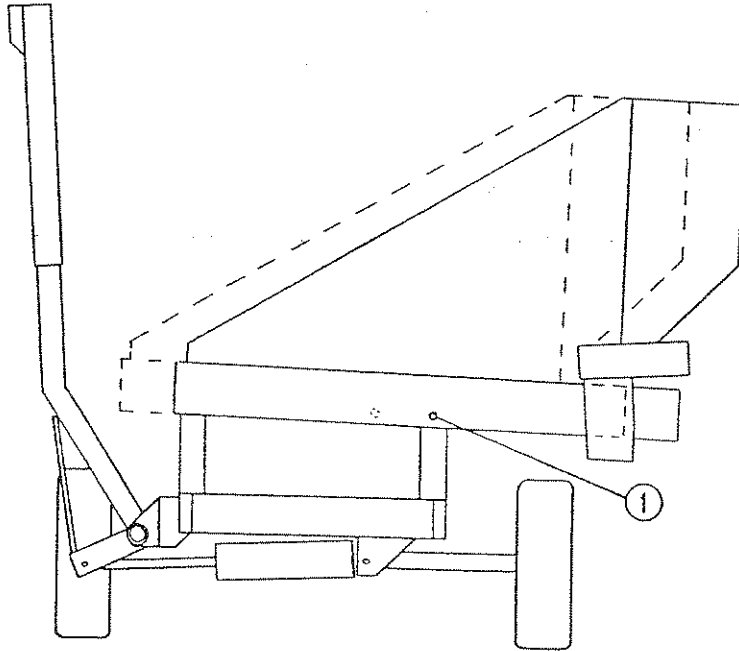

Sketch B (Shown in FEEDING POSITION)

----- WARNING -----

OPERATING THE SUPER SLICER LIFTING ARM WITH THE TABLE  
IN THE ROADING POSITION WILL DO DAMAGE TO THE LIFT  
ARM LINKAGE!

BEFORE OPERATING YOUR NEW SUPER SLICER MAKE A COMPLETE  
INSPECTION OF ALL COMPONENTS TO INSURE THAT ALL THE NUTS  
AND BOLTS ARE TIGHT AND THAT NO DAMAGE HAS OCCURRED DURING  
SHIPPING.

## OPERATING INSTRUCTIONS

### Hydraulic Requirements

Your new DEWEZE SUPER SLICER is designed to be used as a mobile feeding unit mounted on a trailer or as a stationary unit in a permanent installation. Regardless of the type of use the SUPER SLICER WILL REQUIRE 15 GPM (gallons per minute) OF HYDRAULIC OIL FLOW and A MINIMUM OF 1800 PSI (pounds per square inch) HYDRAULIC PRESSURE TO OPERATE PROPERLY. Be sure that the hydraulic system you intend to use is functioning properly and that the oil is clean and of good quality.

TWO HYDRAULIC REMOTES are required to operate the trailer mounted Super Slicer. One to control the lift arm for loading the bales and the other to operate the slicer table. Each remote must be capable of reversible flow. You may want to mark the remotes to make sure that you hook up the hydraulics the same way each time you use the machine.

### Trailer Tongue Adjustments

Your trailer is equipped with a three position tongue to allow the trailer to be pulled off center. The center position is used for transporting the Super Slicer on the road. The right position moves the machine to the left to make bale pickup easier if the tractor has dual rear wheels. The left tongue position moves the machine to the right to make bale processing easier for tractors with dual rear wheels.

To change the position of the tongue simply remove the retainer pin, move the tongue, and replace the retainer pin.

----- WARNING -----

BE SURE TO REPLACE THE SAFETY CLIP IN THE RETAINER PIN. FAILURE TO DO SO COULD ALLOW THE RETAINER PIN TO COME OUT.

OPERATING INSTRUCTIONS (continued)

Loading Instructions (Trailer Mounted Unit Only)

Approach the bale on its right side with the lift arm lowered to the ground. If your tractor is equipped with dual rear wheels, you may have to reposition the tongue to allow the tractor to pass the bale. (See the instructions above). Cradle the bale in the lift fork by moving forward so that the bale is against the back of the fork. Lift the bale all the way up so that the bale rolls onto the table slats. Move the bale toward the sickle by activating the feeder and stop as the bale reaches the sickle. To load and carry a second bale, repeat the above process and raise the second bale until it rests snugly against the first.

BE SURE TO RAISE THE LIFT ARM TO THE UPRIGHT POSITION AND LATCH THE SAFETY CHAIN WHENEVER YOU TRANSPORT YOUR SUPER SLICER ON THE ROAD!

Feeding Instructions

To engage the feeding operation of the Super Slicer; idle the tractor engine, engage the slicer table hydraulics and increase the engine speed to 1200 RPM. This is the optimum speed for processing for most tractors and will process an average bale in approximately four minutes at the minimum feeder setting.

----- DANGER -----

STAY CLEAR OF TABLE AND CUTTER BAR WHEN MACHINE IS  
IN OPERATION!

If the system stalls, reverse the slats and try again. If stalling continues, increase the RPMs of the tractor about 10 percent.

ALWAYS WAIT UNTIL THE FIRST BALE HAS BEEN PROCESSED COMPLETELY AND THE TABLE SLATS HAVE STOPPED BEFORE LOADING THE SECOND BALE ONTO THE TABLE.



OPERATING INSTRUCTIONS (continued)

----- WARNING -----

EXCESSIVE SICKLE SPEED MAY CAUSE TABLE VIBRATION AND  
DAMAGE TO THE HYDRAULIC MOTOR AND/OR THE SICKLE!

Feeding Rate

The feeding rate may be adjusted by changing the speed of the feeder chain, or by adjusting the distance between the sickle and the table slats. To change this distance, use the following procedure.

----- DANGER -----

TURN OFF TRACTOR AND DISCONNECT THE HYDRAULIC HOSES  
BEFORE MAKING ANY ADJUSTMENTS TO THE SICKLE! FAILURE  
TO DO SO COULD RESULT IN SERIOUS PERSONAL INJURY!

1. Loosen the four 5/8" bolts (1) that hold the sickle bar in place. (See Sketch C)

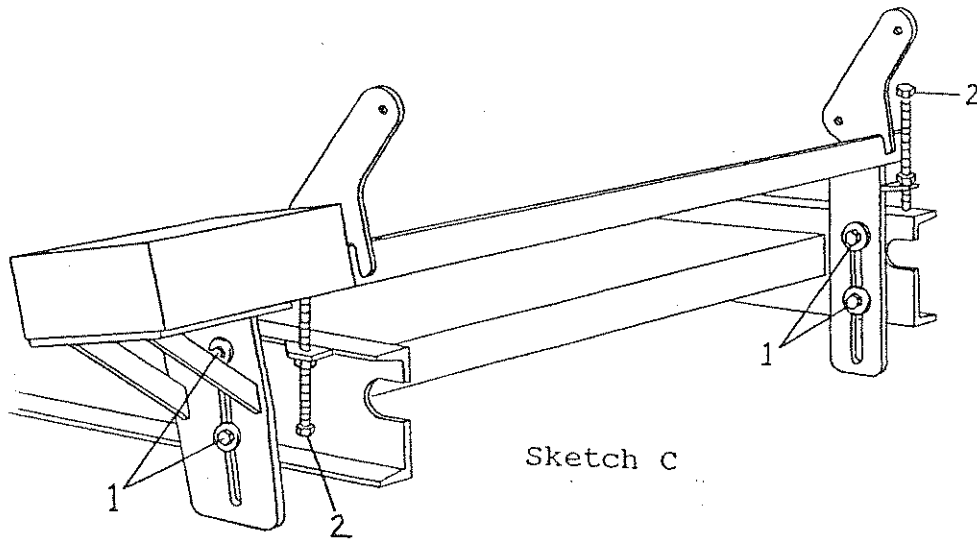

OPERATING INSTRUCTIONS (continued)

Feeding Rate (continued)

2. Screw the 3/4" all thread adjustment bolts (2) in or out at each end of the sickle. Make sure that each end is adjusted so that the sickle is parallel with the table slats. Use a tape measure to gauge each end.

NOTE: THE BACKBOARD WILL SLIDE UP OR DOWN IN RELATION TO THE SIDEBOARDS WITHOUT LOOSENING ANY OTHER BOLTS.

3. Retighten the four 5/8" bolts loosened in step one on previous page.
4. Adjust the Pitman rod assembly as follows to set the sickle register. (Sketch D)
  - A. Loosen two 3/8" socket head screws (1) on turnbuckle.
  - B. Rotate Pitman arm turnbuckle (2) 1-1/2 times for every one inch that the thickness was changed. (Step two above).

SHORTEN THE ARM when reducing the thickness of cut.

LENGTHEN THE ARM when increasing the thickness of cut.

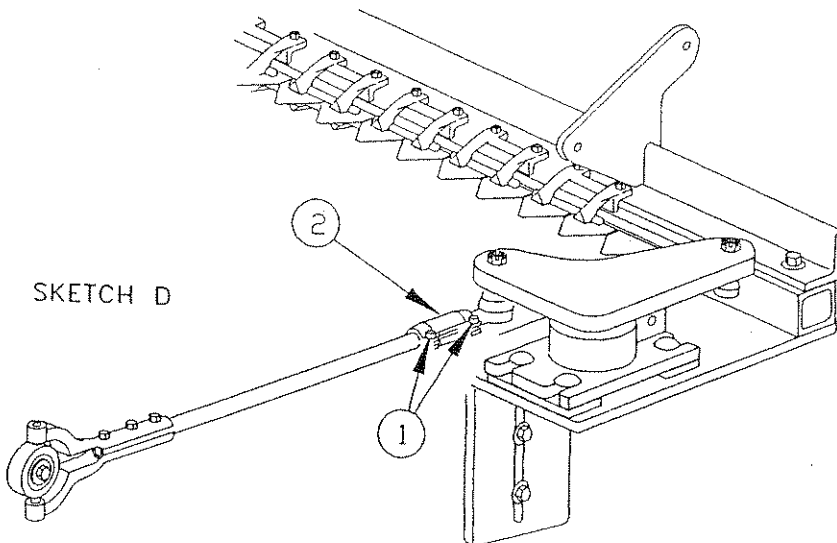

- C. Retighten the 3/8" socket head screws loosened in Step A above.

## OPERATING INSTRUCTIONS (continued)

### Flow Control Valve Adjustment

The flow control valve on the right controls the speed of the sickle; the valve on the left controls the speed of the slats. To adjust the valves, loosen the knob on the adjusting lever and move the lever to a higher number to increase speed, and to a lower number to decrease speed. After moving the lever, tighten the knob to hold the lever in place.

For initial setting of the valves, set each adjusting lever on "5". Fine tune the speed of the sickle and slats by adjusting the valves individually to get proper cutting for the type of hay you are processing.

### Sickle Drive Adjustment

The sickle and drive are pre-set at the factory. If the drive needs to be set because of loose bolts, sickle change, etc., use the following procedure:

----- DANGER -----

TURN OFF AND DEPRESSURIZE\* THE HYDRAULIC POWER SOURCE BEFORE WORKING ON THE SICKLE IN ANYWAY!

\*Depressurize the hydraulic system by activating the controls both ways with the system off.

1. Disconnect the chain coupler (1) of the drive motor. (Sketch E)

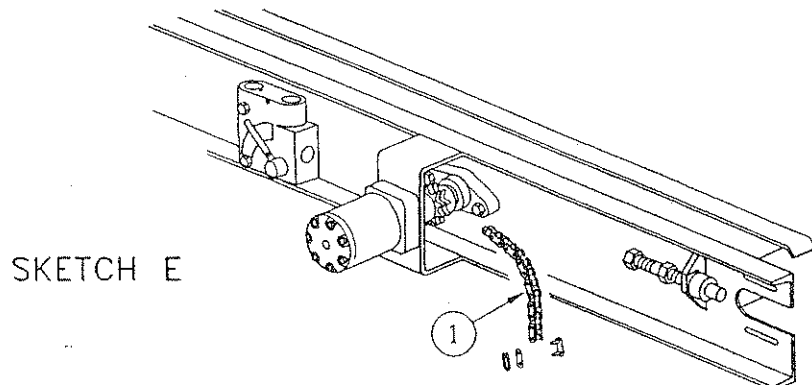

OPERATING INSTRUCTIONS (continued)

Sickle Drive Adjustment (continued)

2. Loosen 4 bolts (1) on Bell Crank (2). (See Sketch F) Position the Bell Crank so that the Bell Crank arm connected to the sickle head (3) is perpendicular to the pitman rod (4). Use a square as shown to set the center line of the arm perpendicular. The center of the sickle sections (5) should be midway between the points of the stub guards (6). If not, adjust the tie rod end on the sickle head to center the sickle sections.

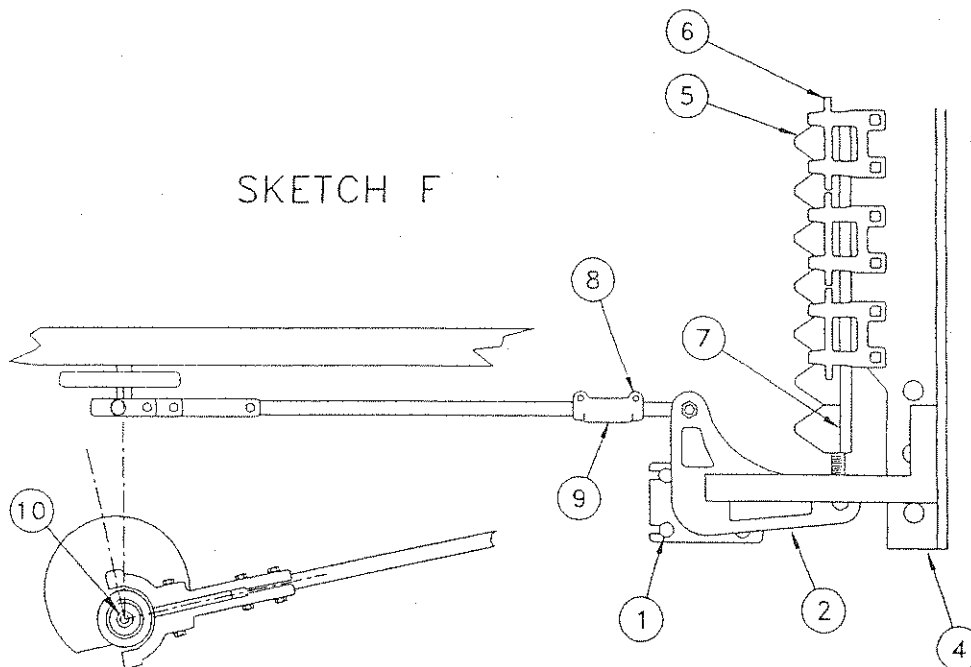

3. Adjust the Bell Crank so there is no more than 1/16" clearance between sickle bar (7) and back of stub guard. Tighten 4 mounting bolts.
4. Keeping Bell Crank in perpendicular position, loosen the 3/8" socket head screws (8), and adjust the Pitman Arm Turnbuckle (9) until the Pitman Arm mounting bolt (10) is either TOP DEAD CENTER or BOTTOM DEAD CENTER. Tighten socket head screws.
5. BE SURE THAT ALL GUARDS AND SHIELDS ARE BACK IN PLACE BEFORE OPERATING THE MACHINE.

## MAINTENANCE INSTRUCTIONS

### Trailer Maintenance

- MONTHLY  
(Every  
100 bales)
- \* Grease the linkage of the lift arm to avoid binding and rust.
  - \* Lubricate the system drive chains with chain oil.
- ANNUALLY
- \* Clean and repack the wheel bearings.

### Sickle Bar Maintenance

- MONTHLY  
(Every  
100 bales)
- \* Grease the Pitman drive bearings, one grease fitting per bearing.
  - \* Grease knuckle joints on Pitman arm (two fittings)
  - \* Check the conveyor chain for tightness. The chain should not swag more than 6" from the bottom of the table at the center. Adjust the take-up roller equally at each end for maximum chain life.

### Drive Shaft Maintenance

- MONTHLY  
Every  
100 bales)
- \* Grease all grease zerks on the drive shaft. (zerks located at each end and one in the middle of the shaft.)
  - \* Inspect and replace any broken or missing safety shields.
  - \* Check for loose bolts on drive shaft

# TRAILER AND FORK ASSEMBLY

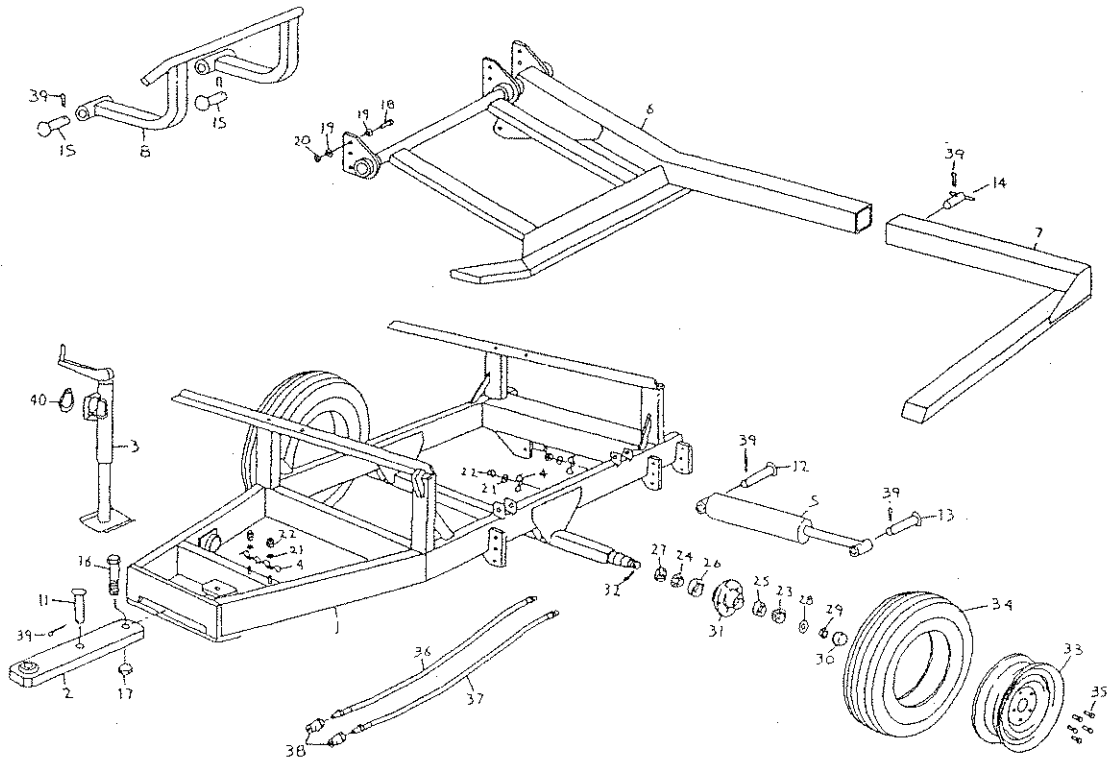

ITEM	PART #	DESCRIPTION
1.	410383	TRAILER FRAME
2.	410008	TONGUE
3.	410048	SWIVEL JACK
4.	410101	HOSE CLIP (2)
5.	420014	CYLINDER
6.	410715	FORK
7.	410026	OUTER FORK ARM
8.	410399	SHAFT, BALE LIFT ARM
9.	-----	-----
10.	-----	-----
11.	410011	CLEVIS PIN
12.	410176	PIN, CYLINDER BASE
13.	410022	PIN, CYLINDER SHAFT
14.	410069	PIN, OUTER ARM
15.	410037	PIN, BALE LIFT ARM (2)
16.	410264	1 x 3.5 NC BOLT
17.	410293	1" NC NUT
18.	510218	1/2 x 1.5 NC BOLT (9)
19.	410265	1/2 FLAT WASHER
20.	510225	1/2 NC NUT
21.	510195	5/16 FLAT WASHER
22.	510208	5/16 NC NUT
23.	410103	OUTER BEARING
24.	410104	INNER BEARING
25.	410115	CUP, OUTER
26.	410114	CUP, INNER
27.	410105	SEAL, BEARING
28.	410109	WASHER
29.	410108	CASTLE NUT
30.	410112	DUST CAP
31.	410111	HUB
32.	410110	COTTER PIN
33.	410107	WHEEL
34.	410113	TIRE
35.	410106	LUG BOLT
36.	420011	HOSE ASSEMBLY
37.	420006	HOSE ASSEMBLY
38.	420005	PIONEER COUPLER, MALE
39.	510175	COTTER PIN
40.	410275	JACK MOUNT & LOCK RING

BACKBOARD & SIDEBOARD ASSEMBLY

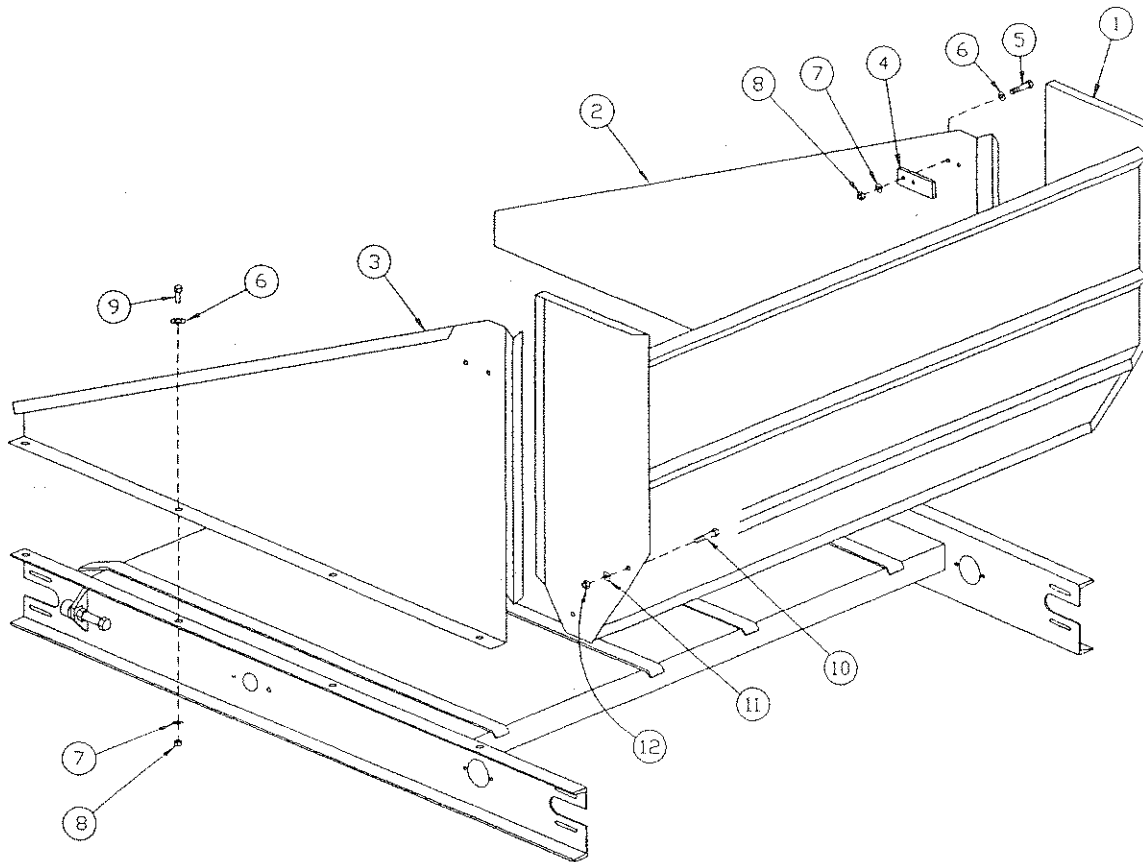

ITEM	PART #	DESCRIPTION
1.	410196	BACKBOARD ASSEMBLY
2.	410076	SIDE, RIGHT
3.	410075	SIDE, LEFT
4.	410135	RETAINER (2)
5.	510063	3/8 NC X 1.0 BOLT (4)
6.	510365	3/8 FLAT WASHER (12)
7.	510271	3/8 LOCK WASHER (12)
8.	510272	3/8 NC NUT (12)
9.	510113	3/8 NC X 1.25 BOLT (8)
10.	510218	1/2 NC X 1.50 BOLT (4)
11.	410283	1/2 FLAT WASHER (4)
12.	210350	1/2 WIZ NUT (4)

# SICKLE DRIVE ASSEMBLY

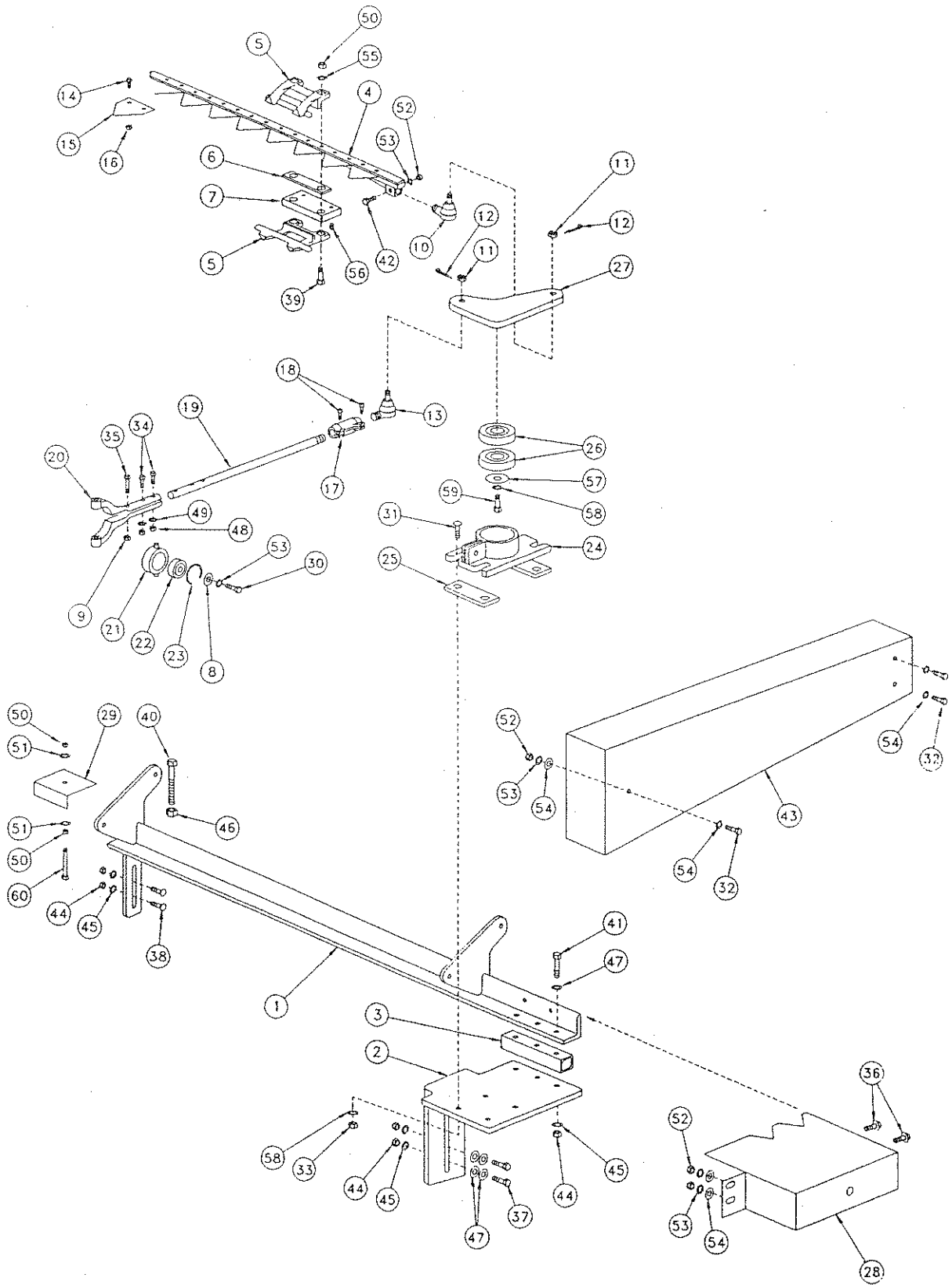



SICKLE DRIVE ASSEMBLY

ITEM	PART #	DESCRIPTION			
1	410384	ANGLE MOUNT / SICKLE	32	510113	3/8 NC X 1.25 BOLT
2	410145	PITTMAN ARM BRACKET	33	510225	1/2 NC NUT
3	410394	SPACER	34	410216	5/16 NC X 2.5 BOLT
4	410191	SICKLE ASSY	35	410217	3/8 NC X 3.5 BOLT
5	400031	GUARD	36	510401	3/8 NC X .75 WIZ BOLT
6	410711	SHIM	37	310202	5/8 NC X 2.0 BOLT
7	410710	SPACER	38	410204	5/8 NC X 2.0 CARR. BOLT
8	500128	CUSTOM FLAT WASHER	39	110054	7/16 NC X 2.5 CARR. BOLT
9	510491	3/8 LOCK NUT	40	410126	ADJUSTMENT SCREW
10	410186	TIE ROD END (RH)	41	410395	5/8 NC X 5.0 BOLT
11	410218	CASTLE NUT	42	410267	3/8 NC X 2.0 BOLT
12	410261	COTTER PIN	43	410393	SHIELD / PITTMAN ARM
13	410189	TIE ROD END (LH)	44	410205	5/8 NUT
14	400024	BOLT / SECTION	45	410206	5/8 LOCK WASHER
15	400019	SICKLE SECTION	46	410201	3/4 NUT
16	400021	LOCK NUT / SECTION	47	510080	5/8 FLAT WASHER
17	410183	TURNBUCKLE	48	510208	5/16 NUT
18	410215	SOCKET HEAD CAP SCREW	49	510335	5/16 LOCK WASHER
19	410197	PITTMAN ROD	50	710512	7/16 NUT
20	410190	PITTMAN ARM	51	510258	7/16 FLAT WASHER
21	410187	BEARING HOUSING	52	510272	3/8 NUT
22	410188	BEARING	53	510271	3/8 LOCK WASHER
23	410513	RETAINING RING	54	510365	3/8 FLAT WASHER
24	410184	BEARING HOUSING	55	510260	7/16 LOCK WASHER
25	410121	SHIM	56	510161	3/8 SET SCREW
26	410194	BEARING / BELL CRANK	57	410271	CUSTOM WASHER
27	410185	BELL CRANK	58	510219	1/2 LOCK WASHER
28	410148	SHIELD / BELL CRANK	59	110086	1/2 NC X 1.0 BOLT
29	410150	END SHIELD / SICKLE	60	710524	7/16 NC X 2.5 BOLT
30	510063	3/8 NC X 1.0 BOLT			
31	410635	CARRIAGE BOLT			

TABLE ASSEMBLY

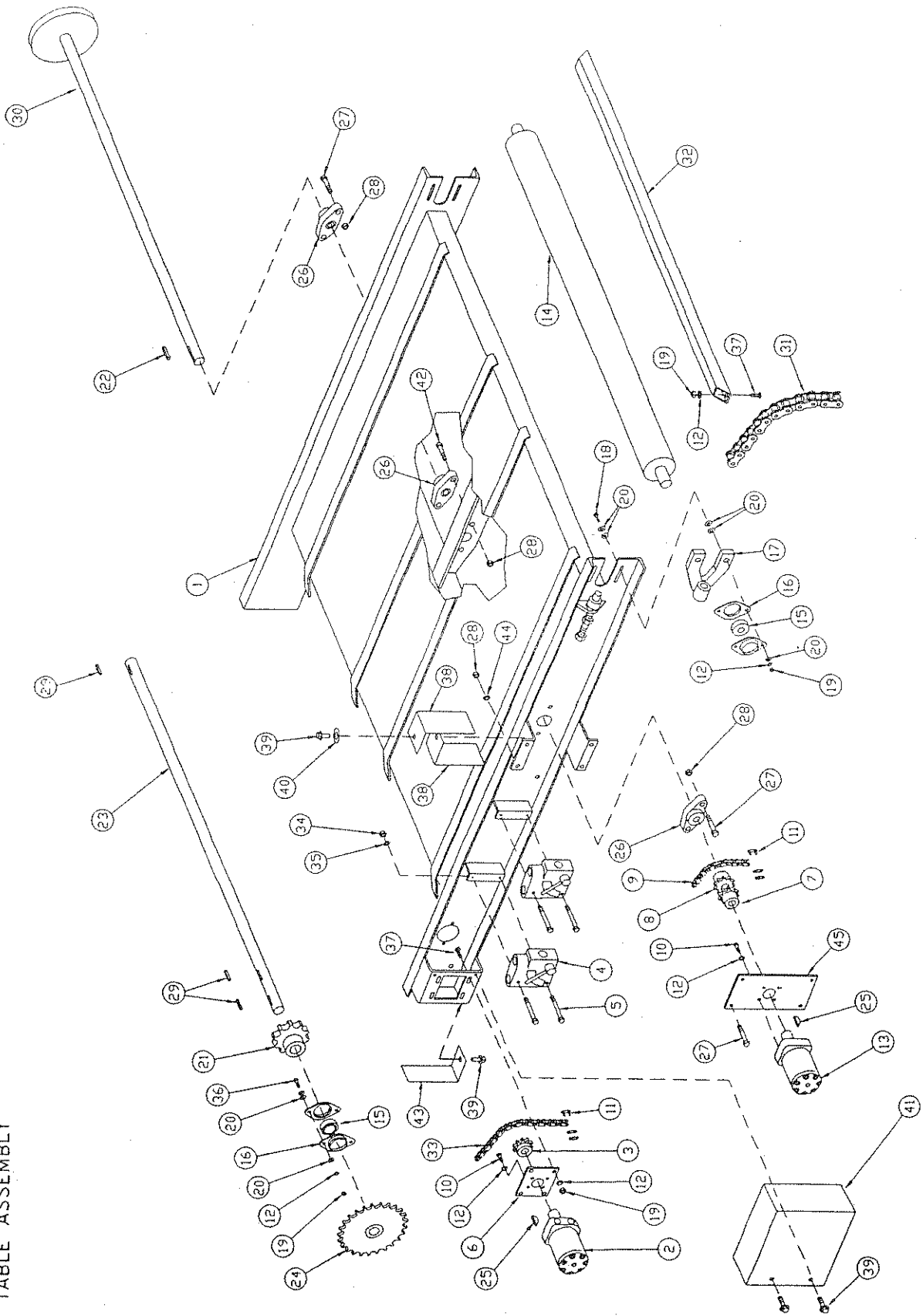
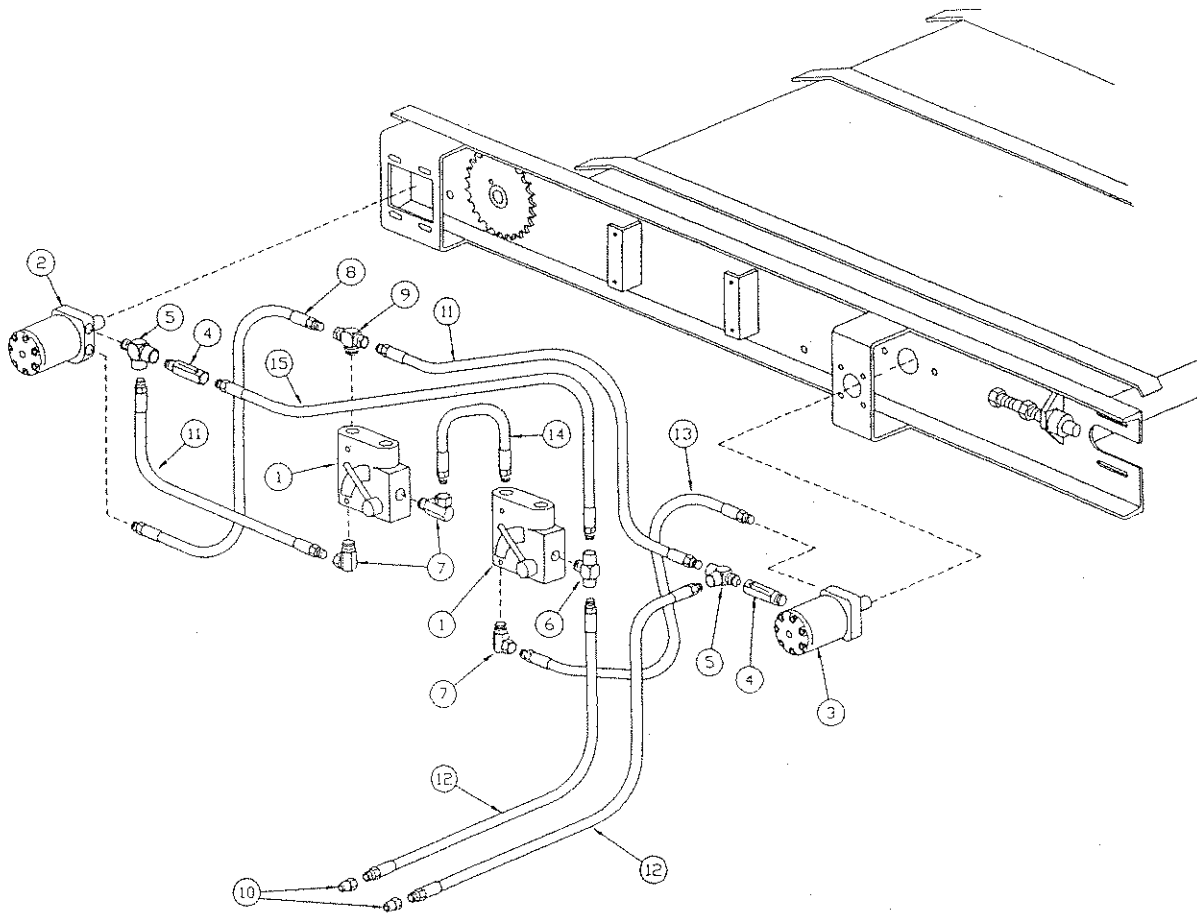

TABLE ASSEMBLY

ITEM	PART #	DESCRIPTION			
1	410279	TABLE WELD ASSEMBLY		410372	SPROCKET
2	420016	SLAT DRIVE MOTOR		410321	1/4 X 1.0 WOODRUFF KEY
3	410375	DRIVE SPROCKET		410243	BLOCK BEARING
4	420048	FLOW CONTROL		510218	1/2 NC X 1.5 BOLT
5	410526	1/4 NC X 2.5 BOLT		510396	1/2 NC LOCK NUT
6	410365	MOTOR MOUNT		410238	1/4 X 1/4 X 2.25 SQ KEY
7	410229	OUTSIDE COUPLER		410244	SICKLE DRIVE SHAFT
8	410262	INSIDE COUPLER		410224	SLAT CHAIN ASSEMBLY
9	410230	COUPLER CHAIN		410612	SLAT
10	510063	3/8 NC X 1.0 BOLT		410373	DRIVE CHAIN
11	410442	MASTER LINK		510224	1/4 NC NUT
12	510271	3/8 LOCK WASHER		510221	1/4 LOCK WASHER
13	420033	SICKLE DRIVE MOTOR		510113	3/8 NC X 1.25 BOLT
14	410170	ROLLER		410272	3/8 NC X 1.25 CARR. BOLT
15	410232	BEARING		410371	SICKLE MOTOR SHIELD
16	410233	FLANGE		510401	3/8 NC X 3/4 WIZ BOLT
17	410281	ROLLER MOUNT BRACKET		410265	1/2 FLAT WASHER
18	410267	3/8 NC X 2.0 BOLT		410369	SLAT DRIVE SHIELD
19	510272	3/8 NUT		500238	1/2 NC X 1.75 BOLT
20	510365	3/8 FLAT WASHER		410370	SPROCKET SHIELD
21	410237	SLAT CHAIN SPROCKET		510219	1/2 LOCK WASHER
22	410389	5/16 X 5/16 X 1.25 SQ KEY		410746	ORBIT MOTOR PLATE
23	410102	SPROCKET SHAFT			

# HYDRAULICS ASSEMBLY



ITEM	PART #	DESCRIPTION
1.	420048	FLOW CONTROL
2.	420016	SLAT DRIVE MOTOR
3.	420033	SICKLE DRIVE MOTOR
4.	420035	CHECK VALVE
5.	420036	TEE ADAPTER
6.	420037	TEE ADAPTER
7.	420039	ADAPTER
8.	420027	HOSE ASSEMBLY
9.	420049	TEE ADAPTER
10.	420005	QUICK DISCONNECT
11.	420031	HOSE ASSEMBLY (2)
12.	420001	HOSE ASSEMBLY (2)
13.	420024	HOSE ASSEMBLY
14.	420026	HOSE ASSEMBLY
15.	420047	HOSE ASSEMBLY

PTO DRIVEN SUPER SLICER

Your Deweze Super Slicer can be converted to or purchased as a power take-off driven unit.

The following pages indicate the parts and hose routing required for a drive shaft option.

**CAUTION**

ALWAYS SHIFT THE PTO IN GEAR WITH THE TRACTOR ENGINE AT AN IDLE OR THE SHEAR BOLT WILL FAIL PREMATURELY

**WARNING**

NEVER OPERATE YOUR DEWEZE SUPER SLICER WITH WORN, STRESSED OR MISSING DRIVE LINE PARTS

**DANGER**

ALWAYS KEEP ALL GUARDS AND SHEILDS  
IN PLACE AT ALL TIMES

TABLE ASSEMBLY / PTO OPTION

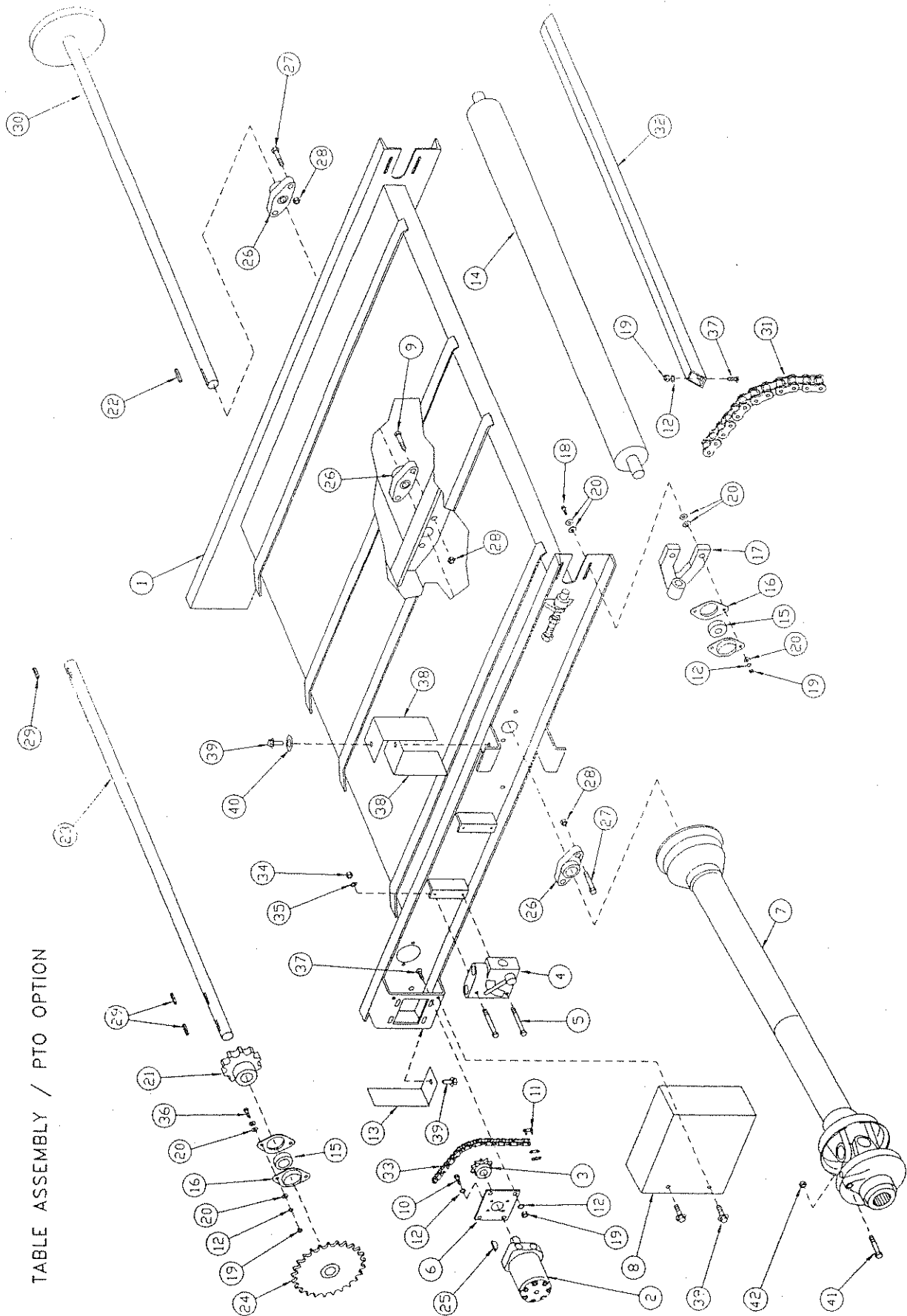
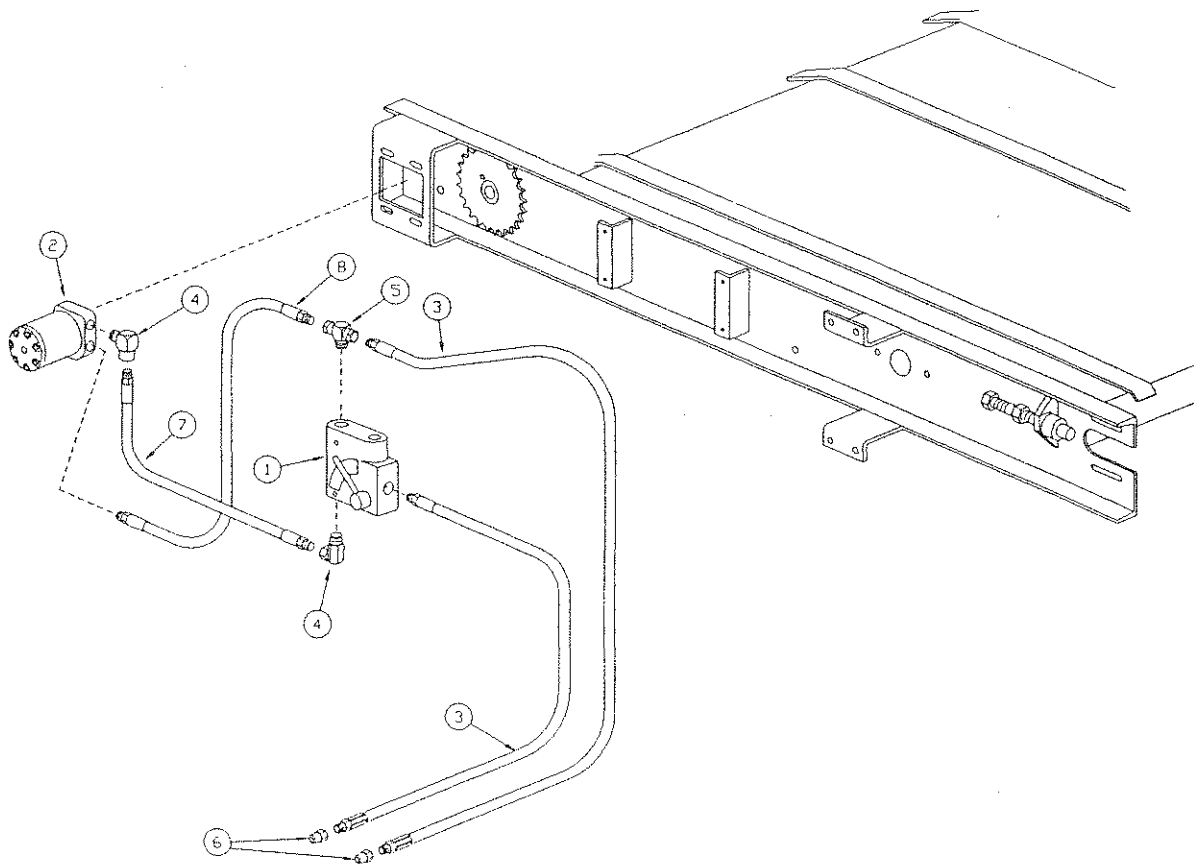

TABLE ASSEMBLY WITH PTO OPTION

ITEM	PART #	DESCRIPTION			
1	410279	TABLE WELD ASSEMBLY			
2	420016	SLAT DRIVE MOTOR			
3	410375	DRIVE SPROCKET			
4	420048	FLOW CONTROL			
5	410526	1/4 NC X 2.5 BOLT			
6	410365	MOTOR MOUNT			
7	410752	PTO SHAFT ASSEMBLY			
8	410369	SLAT DRIVE SHIELD			
9	500238	1/2 NC X 1.75 BOLT			
10	510063	3/8 NC X 1.0 BOLT			
11	410442	MASTER LINK			
12	510271	3/8 LOCK WASHER			
13	410370	SPROCKET SHIELD			
14	410170	ROLLER			
15	410232	BEARING			
16	410233	FLANGE			
17	410281	ROLLER MOUNT BRACKET			
18	410267	3/8 NC X 2.0 BOLT			
19	510272	3/8 NUT			
20	510365	3/8 FLAT WASHER			
21	410237	SLAT CHAIN SPROCKET			
			22	410389	5/16 X 5/16 X 1.25 SQUARE KEY
			23	410102	SPROCKET SHAFT
			24	410372	SPROCKET
			25	410321	1/4 X 1.0 WOODRUFF KEY
			26	410243	BLOCK BEARING
			27	510218	1/2 NC X 1.5 BOLT
			28	500203	1/2 NC LOCK NUT
			29	410238	1/4 X 1/4 X 2.25 SQUARE KEY
			30	410244	SICKLE DRIVE SHAFT
			31	410224	SLAT CHAIN ASSEMBLY
			32	410167	SLAT
			33	410373	DRIVE CHAIN
			34	510224	1/4 NC NUT
			35	510221	1/4 LOCK WASHER
			36	510113	3/8 NC X 1.25 BOLT
			37	410272	3/8 NC X 1.25 CARRAIGE BOLT
			38	410371	SICKLE MOTOR SHIELD
			39	510401	3/8 NC X 3/4 WIZ BOLT
			40	410265	1/2 FLAT WASHER
			41	110091	5/16 NC X 1.0 SHEAR BOLT
			42	410222	5/16 NC LOCK NUT

HYDRAULICS ASSEMBLY / PTO OPTION



ITEM	PART #	DESCRIPTION
1.	420048	FLOW CONTROL
2.	420016	SLAT DRIVE MOTOR
3.	420001	HOSE ASSEMBLY (2)
4.	420039	ADAPTER
5.	420049	TEE ADAPTER
6.	420005	QUICK DISCONNECT
7.	420031	HOSE ASSEMBLY
8.	420027	HOSE ASSEMBLY





## STATEMENT of WARRANTY

### DewEze Clutch Pump Kits

DewEze Mfg., warrants to each purchaser of new DewEze clutch pump kits from an authorized dealer or representative, that such kits are free from manufacturing defects which appear while in normal service for a period on ONE YEAR, unless otherwise specified, commencing with the delivery to the original user.

DewEze warranty policy on clutch pumps kits covers the replacement of defective parts and freight (regular ground UPS) to the dealer. IT DOES NOT COVER THE LABOR REQUIRED TO REPLACE DEFECTIVE PARTS.

DewEze, however, limits all warranties, expressed or implied, including warranties of merchantability and fitness for a particular purpose, to repair or replacement. The decision to repair or replace shall be a DewEze's option. DewEze does not warrant, and is not responsible for, any damage to the engine or any component thereof, on which the clutch pump kit is mounted. DewEze Mfg., makes no other express warranty, nor is anyone authorized to make any on its behalf.

## Returned Goods / Warranty Procedure

- 1) Call a DewEze Service Representative whenever parts need to be returned or a warranty problem occurs. An RGA (Returned Goods Authorization) / Warranty number will be issued at that time for each shipment of parts and/or service job done under warranty.
- 2) Write RGA / Warranty number on four-sheet form provided by DewEze, and fill out completely with **Dealer account number, name, date, machine information, part numbers, descriptions, etc.**
- 3) RGA / Warranty forms must be completed and returned to DewEze within 60 days from when service job under warranty is done.
- 4) Return parts within 30 days from date that RGA / Warranty number is issued.
- 5) Send top three sheets to DewEze (along with parts if possible). Fourth sheet is Dealer's copy. Incomplete forms will be returned to Dealer.
- 6) Write RGA / Warranty number on outside of box containing returned parts and ship to DewEze (along with forms if possible).
- 7) All parts must be cleaned of excess grease, oil, etc. Cylinders, hoses and pumps must be drained of oil or a clean-up fee may be charged.
- 8) Dealer is responsible for cost of returning parts to DewEze, and any practical method of shipment may be used.
- 9) A restocking fee is charged for unused or slow moving parts ordered by Dealer, and returned to DewEze (15% of Dealer cost for parts, 15% up to \$40 for clutch pump kits).
- 10) For warranty items, DewEze will determine if Dealer needs to return parts for inspection.
- 11) If returned parts are not required, DewEze will ship needed parts immediately at no charge to Dealer. (UPS Ground)
- 12) If parts are acquired locally, rather than gotten from DewEze, DewEze will reimburse expense up to the cost of the comparable DewEze part. Write RGA / Warranty number on receipts and return to DewEze (with forms if possible).
- 13) When parts and/or receipts are received, DewEze will review warranty claims, and a determination will be made.
- 14) Dealer's account will be credited. COD customers may request a check.